

GSM-VAC4+

VOICE & SMS GSM ALARM COMMUNICATOR



INSTALLATION MANUAL

V 2.0

TABLE OF CONTENTS

1 FOR YOUR SAFETY	1
2 INTRODUCTION	2
3 FEATURES AND APPLICATIONS	3
4 START UP	4
5 LED DISPLAY	5
6 CLEAR ALL PROGRAMMED DATA FROM SIM	6
7 CONNECTING DIAGRAM	7
8 VOICE MESSAGES – RECORD & PLAY	8
8.1 RECORDING MODE.....	8
8.2 PLAY.....	8
9 PROGRAMMING MODE	9
9.1 PROGRAMMING TELEPHONE NUMBERS - TN.....	9
9.1.1 TN remote programming by SMS.....	10
9.2 PROGRAMMING INPUT STATUS - IN.....	10
9.2.1 IN parameter remote programming by SMS.....	11
9.3 INPUT FILTER PARAMETR – ID.....	12
9.3.1 Programming table to define the value of the input filter.....	12
9.3.2 ID parameter remote programming by SMS.....	12
9.4 DELAY BEFORE DIAL – DD.....	13
9.4.1 DD remote programming by SMS.....	13
9.5 PROGRAMMING OUTPUT STATUS - OS.....	14
9.5.1 Programming table for output status.....	14
9.5.2 OS remote programming by SMS.....	14
9.6 DIRECT ALARM OUTPUT – OD.....	15
9.6.1 Programming table for OD – direct alarm output.....	15
9.6.2 OD remote programming by SMS.....	15
9.7 INPUTS AND TELEPHONE NO. LINKING - LN.....	16
9.7.1 Programming table for linking the inputs and telephone numbers – LN.....	16
9.7.2 LN remote programming by SMS.....	16
9.8 MAIN POWER LOST AND TELEPHONE NO. LINKING – LN5.....	17
9.8.1 Programming table for the MAIN POWER LOST and telephone numbers linking.....	17
9.8.2 LN remote programming by SMS.....	17
9.9 LOW BATTERY AND TELEPHONE NO. LINKING – LN6.....	17
9.9.1 Programming table for LOW BATTERY and telephone numbers linking.....	18
9.9.2 LN6 remote programming by SMS.....	18
9.10 MAIN POWER LOST FILTER PARAMETER - MAIN	18
9.10.1 Programming table for “MAIN POWER LOST” filter – MAIN.....	18
9.10.2 MAIN POWER LOST - filter remote programming by SMS.....	19
9.11 CLIP FUNCTION PARAMETER – TC.....	19
9.11.1 Programming table to define the CLIP functions – TC.....	19

9.11.2 TC parameter remote programming by SMS.....	20
1.1 AUTOMATIC INPUT BLOCK SYSTEM.....	20
1.1.1 The input time window remote programming by SMS.....	21
1.2 SECURITY LEVEL - SL.....	21
1.2.1 Programming table for security level definition – SL.....	22
1.2.2 SL parameter remote programming by SMS.....	22
1.3 PREPAID CARD CREDIT AND VALIDITY INFORMATION.....	22
1.3.1 Programming prepaid card credit and validity string.....	22
1.3.2 CC parameter for remote programming.....	23
1.4 SET-UP PARAMETERS	23
1.4.1 Set-up parameters programming by SMS.....	25
1.5 SMS MESSAGES EDITOR.....	25
1.5.1 Alarm messages remote editing by SMS command.....	25
2 DTMF REMOTE COMMANDS.....	26
2.1 DTMF REMOTE COMMAND TABLE.....	26
3 PRINT-OUT OF THE PARAMETERS.....	27
3.1 RECEIVE ALL PARAMETERS (PALL)	27
3.2 RECEIVE TELEPHONE NUMBERS (PTN).....	27
3.3 RECEIVE LINKS (PLN).....	27
3.4 RECEIVE INPUT PARAMETERS (PIN).....	27
3.5 RECEIVE INPUT FILTER VALUE (PID).....	27
3.6 RECEIVE DELAY BEFORE DIAL VALUE (PDD).....	27
3.7 RECEIVE CLIP IDENTIFICATION FUNCTIONS (PTC).....	27
3.8 RECEIVE ACCESS TELEPHONE NUMBERS (PSL).....	28
3.9 RECEIVE OUTPUT PARAMETERS (POS).....	28
3.10 RECEIVE LINK FOR LOCAL ALARM OUTPUT (POD).....	28
3.11 RECEIVE ALL PROGRAMMED SMS MESSAGES (P#).....	28
3.12 RECEIVE THE POWER LEVEL ON THE UNIT (PPWR).....	28
3.13 RECEIVE SET UP PARAMETERS VALUE (PPA).....	28
3.14 STATE OF THE CREDIT FOR THE PREPAID CARD.....	28
3.15 STATE OF THE OUTPUTS (PORC).....	28
4 CHECKING AND CHANGING THE SYSTEM STATUS (ON/OFF).....	29
4.1 CHECKING SYSTEM STATUS BY SMS COMMAND.....	29
4.2 CHECKING SYSTEM STATUS BY DTMF COMMAND.....	29
4.3 CHANGING SYSTEM STATUS TO ON (SYSTEM ON).....	29
4.4 CHANGING SYSTEM STATUS TO OFF (SYSTEM OFF).....	29
5 CHECKING THE INPUT STATUS.....	30
5.1 CHECKING THE INPUT STATUS BY DTMF.....	30
5.2 CHECKING THE INPUT STATUS BY SMS (INS).....	30
6 OUTPUTS REMOTE CONTROL	31
6.1 OUTPUTS REMOTE CONTROL BY SMS COMMAND.....	31
6.2 OUTPUTS REMOTE CONTROL BY DTMF COMMAND.....	31

7 CHANGING PARAMETERS USING THE SMS COMMAND.....	32
8 APPENDIX TO GSM-VAC4+ MANUAL FOR CONTACT-ID (REV6).....	33
9 TECHNICAL SPECIFICATION.....	34
18 CONTACT.....	35

1 FOR YOUR SAFETY

Read these simple guidelines. Not following them may be dangerous or illegal. Read the complete user guide for further information.

SWITCH ON SAFELY

Do not switch the unit on when use of wireless phone is prohibited or when it may cause interference or danger.

INTERFERENCE

All wireless phones and units may be susceptible to interference, which could affect performance.

SWITCH OFF IN HOSPITALS

Follow any restrictions. Switch the unit off near medical equipment.

SWITCH OFF IN AIRCRAFT

Follow any restrictions. Wireless devices can cause interference in aircraft.

SWITCH OFF WHEN REFUELING

Do not use the unit at a refueling point. Do not use near fuel or chemicals.

SWITCH OFF NEAR BLASTING

Follow any restrictions. Do not use the unit where blasting is in progress.

USE SENSIBLY

Use only in the normal position as explained in the product documentation. Do not touch the antenna unnecessarily.

2 INTRODUCTION

GSM-VAC4+ communicator is a new mobile voice and SMS autodialler system. It is mostly used to provide wide range of alarm information and very useful remote controls. **GSM-VAC4+** can pass on messages about intrusion alarms, technical alarms, etc. by voice call or SMS to the end-user or directly by sending the Contact ID built-in to the Central Monitoring Station (CMS).

GSM-VAC4+ can be used in connection with different applications such as:

- Security alarm systems
- Home care and Emergency alarm
- Fire systems
- Car and boat alarm transmitter
- Door entry
- Remote access control

3 FEATURES AND APPLICATIONS

Features:

- Built-in 3 or 4 band GSM module
- Contact ID protocol built-in
- 4 alarm inputs
- ON/OFF input
- 4 remotely controlled alarm outputs
- 4 prerecorded alarm messages – 1 for each alarm input
- 15 SMS alarm and service messages
- Memory stores up to 10 different telephone numbers
- Listen-in function
- PC programming by USB SIM card editor
- Download programming by USB port
- Output remotely controlled by SMS, CLIP and DTMF command
- System activating and deactivating by SMS, CLIP and DTMF command
- Up to 1000 event log buffer

Applications:

- Security alarm systems
- Home care and Emergency alarm
- Fire systems
- Car and boat alarm transmitter
- Door entry
- Remote access control
- Temperature regulations
- Vending Machines
- Other remote controls

4 START UP

- ⇒ Insert SIM card to be used for GSM-VAC4+ in your personal mobile phone.
- ⇒ **ERASE THE PIN CODE!**
- ⇒ Enter telephone numbers and the required operating parameters in SIM memory – at least 1 telephone No. (TN1) and 1 link (LN1) should be programmed (see installation manual).
- ⇒ Insert SIM card in the GSM module applied for the GSM-VAC4+ device. The unit must be power OFF when you insert the SIM!
- ⇒ Connect alarm inputs and outputs to GSM-VAC4+.
- ⇒ Connect the antenna to antenna connector.
- ⇒ Connect device to source power supply voltage.
- ⇒ Wait until LED3 display is turned ON (green) and LED1 (blue) starts flashing. This is set in around 1 minute.
- ⇒ Connect the headset to Play/REC connector and record alarm messages.
- ⇒ GSM-VAC4+ unit is now ready to operate.

NOTE: When the back-up battery 12V/1,2Ah is connected to the unit the main power supply must be from 13,8V to 14,5V DC!

5 LED DISPLAY

Blue LED (LED1)

- Indicates the level of the GSM signal from 1 to 5 LED flashes (1 is weak signal, 5 is excellent signal)

Red LED (LED2)

- When LED 2 is ON the unit has a problem with a GSM network connection or the GSM part of the unit is out of order. In this case immediately call the service!

Red LED (LED2) – alarm state

- During an alarm event the red LED indicates on which input alarm has been triggered. For example if alarm was triggered on the first input there is 1 LED flash, on second input 2 LED flashes, etc.

Green LED (LED3)

- When the alarm inputs on the unit are in active state (SYS=1) then the green LED is ON. With alarm inputs disabled the green LED goes OFF (SYS=0).

Yellow LED (LED4)

- Short flashing indicates that the GSM module is ON, but it is not yet connected on the GSM network. After connection, yellow led is flashing with short pulse ON and a long pulse OFF.

6 CLEAR ALL PROGRAMMED DATA FROM SIM

WARNING!!! By sending this command to the GSM-VAC4+ all programmed data are erased from the SIM card!

This is highly recommended when a SIM card you are going to use for the GSM-VAC4+ is not new and it already has some data stored in the phone book memory.

By sending this SMS to GSM-VAC4+ all programmed parameters and numbers are cleared:
;SDCLR;

After sending SMS you should wait at least 30 second for the command to be executed!

7 CONNECTING DIAGRAM

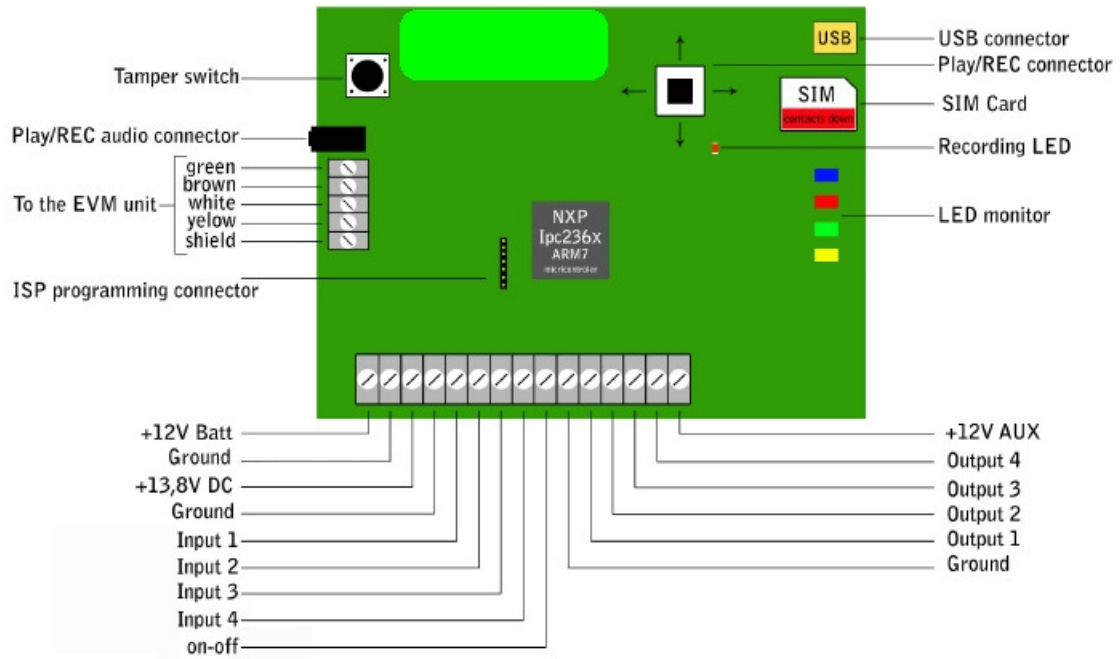

8 VOICE MESSAGES – RECORD & PLAY

The memory of each alarm input enables us to record our own voice message in the total length of 10 seconds. The device is namely equipped with a PLAY/REC audio connector. For recording and listening recorded message a headset is necessary. Headset is very common and it is use with many mobile phones but should be supplied also by your distributor.

8.1 RECORDING MODE

For recording and playing alarm messages GSM-VAC4+ has a joystick switch which you can use in 4 different directions:

- Message 1 – UP
- Message 2 – RIGHT
- Message 3 – DOWN
- Message 4 – LEFT

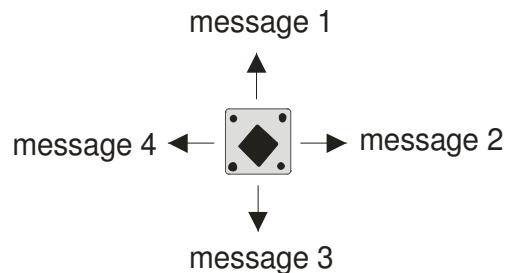

To start recording mode push the PLAY/REC joystick into one direction (depending which message you would like to record) and hold the stick in this position. After the beep you can start with recording and stop recording when you hear two short beeps. REC/PLAY procedure is indicating by REC/PLAY LED as well. REC/PLAY LED is flashing during recording or playing procedure.

Follow the same procedure for all four alarm messages.

8.2 PLAY

Press the PLAY/REC joystick into one direction for a short time (around 1 second) and you will hear the recorded message.

To stop play mode press the PLAY/REC joystick again for a second and play mode will stop.

Follow the same procedure for all four messages.

9 PROGRAMMING MODE

IMPORTANT!!!

Before you insert SIM card into the holder of GSM module or external GSM phone please disable the PIN CODE!!!!

To program GSM-VAC4+ parameters put the SIM card into your personal GSM phone. Add programming parameters in **SIM Card “Phone Book”**.

GSM-VAC4+ is possible to program on 4 different ways:

- ⇒ Using the USB SIM manager on the PC - recommended
- ⇒ Directly on SIM card using personal mobile phone
- ⇒ Remotely by SMS command
- ⇒ With PC Via USB port*

* Not supported yet

NOTE: When you use new or empty SIM card or when parameters were not yet programmed GSM-VAC4+ automatically sets the default values (see table).

9.1 PROGRAMMING TELEPHONE NUMBERS - TN

PROGRAMMING TABLE – DIRECT PROGRAMMING ON THE SIM CARD
Default values:

GSM-VAC4+ PROGRAMMING TABLE		
SIM CARD PHONE BOOK		
Name	Number (Default)	Description
TN1		1 st telephone number
TN2		2 nd telephone number
TN3		3 rd telephone number
TN4		4 th telephone number
TN5		5 th telephone number
TN6		6 th telephone number
TN7		7 th telephone number
TN8		8 th telephone number
TN9		9 th telephone number
TN0		10 th telephone number

GSM-VAC4+ sends an alarm prerecorded voice messages, an alarm SMS messages or both. If the corresponding name ends with the letter “V”, only voice message is sent and if the name ends with the letter “M” only SMS message is sent.

By pressing * on your phone you switch OFF the redial call for calling number. The remaining numbers are called as usual. By pressing # you switch off all remaining calls.

Example: When you need to send an alarm beep message and SMS message to the first telephone number, only alarm beep message to the second one and only SMS message to the third one. (See the table below.)

GSM-VAC4+ PROGRAMMING TABLE		
SIM CARD PHONE BOOK		
Name	Number	Description
TN1	042376678	1st telephone number (alarm voice & SMS message)
TN2V	040719479	2nd telephone number (alarm voice only)
TN3M	040308350	3rd telephone number (SMS message only)

9.1.1 TN remote programming by SMS

For the upper example send the following SMS from the host phone to the GSM-VAC4+:
;TN1=042376678;TN2V=040719479;TN3M=040308350;

If you would like to receive confirmation SMS write “+” before SMS command:
++;TN1=042376678;TN2V=040719479;TN3M=040308350;

9.2 PROGRAMMING INPUT STATUS - IN

Alarm and reset input can be triggered in 4 different ways. The status of the input can either be normal closed (N.C) or normal open (N.O.) with positive (+ 12V) or negative (GND) voltage.

When you need the input feedback information it is possible to receive SMS back when input will return from alarm to normal position. (See cap.5.8 – SMS Messages organizer). To get return SMS use IN=4,5 or 6.

- ⇒ IN = 0 – Normal Open – triggered with negative voltage (GND)
- ⇒ IN = 1 – Normal Close – breaking negative or positive voltage loop
- ⇒ IN = 2 – Normal Open – triggered with positive voltage (+ 12VDC)
- ⇒ IN = 3 – Input disable
- ⇒ IN = 4 = IN = 0 + input reset SMS
- ⇒ IN = 5 = IN = 1 + input reset SMS
- ⇒ IN = 6 = IN = 2 + input reset SMS

TYPICAL INPUT CONNECTIONS

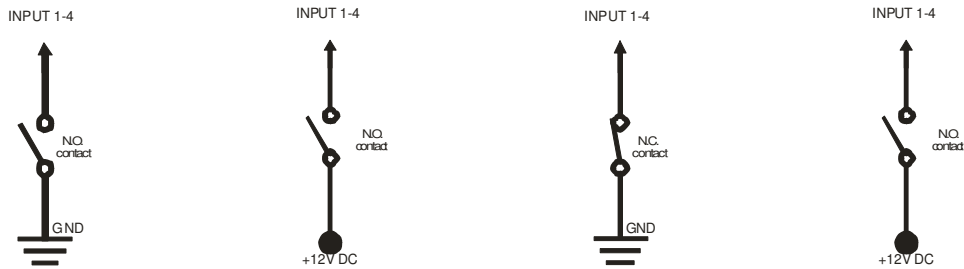

PROGRAMMING TABLE FOR INPUT STATUS

Default values:

GSM-VAC4+ PROGRAMMING TABLE		
SIM CARD PHONE BOOK		
Name	Number (Default)	Description
ION	0	Input status for system ON/OFF
IN1	0	Input status for alarm input 1
IN2	0	Input status for alarm input 2
IN3	0	Input status for alarm input 3
IN4	0	Input status for alarm input 4

Example:

GSM-VAC4+ PROGRAMMING TABLE		
SIM CARD PHONE BOOK		
Name	Number	Description
ION	0	OFF – connecting GND on ON/OFF input
IN1	0	Alarm activated by connecting to GND
IN2	1	Alarm activated by disconnecting GND or +12V
IN3	2	Alarm activated by connecting +12V
IN4	4	Alarm activated by connecting to GND + RST SMS

9.2.1 IN parameter remote programming by SMS

For the upper example send the following SMS from the host phone to the GSM-VAC4+:
;ION=0;IN1=0;IN2=1;IN3=2;IN4=4;

If you would like to receive confirmation SMS write “+” before SMS command:
++;ION=0;IN1=0;IN2=1;IN3=2;IN4=4;

9.3 INPUT FILTER PARAMETR – ID

ID parameter determines time period of the pulse length to trigger the Input. The pulse time can be from 0,5 seconds to 9999 seconds. The default time is 0,5 seconds when the parameter value is 0.

9.3.1 Programming table to define the value of the input filter

Default values:

GSM-VAC4+ PROGRAMMING TABLE		
SIM CARD PHONE BOOK		
Name	Number (Default)	Description
DON	0	Default ID filter is 0,5 seconds – ON/OFF input
ID1	0	Default ID filter is 0,5 seconds – input 1
ID2	0	Default ID filter is 0,5 seconds – input 2
ID3	0	Default ID filter is 0,5 seconds – input 3
ID4	0	Default ID filter is 0,5 seconds – input 4

Example:

GSM-VAC4+ PROGRAMMING TABLE		
SIM CARD PHONE BOOK		
Name	Number	Description
DON	0	Default ID filter is 0,5 seconds – ON/OFF input
ID1	5	ID filter is 5 seconds for input 1
ID2	30	ID filter is 30 seconds for input 2
ID3	2	ID filter is 2 seconds for input 3
ID4	0	ID filter is 0,5 seconds for input 4

9.3.2 ID parameter remote programming by SMS

For the upper example send the following SMS from the host phone to the GSM-VAC4+:
;ID1=5;ID2=30;ID3=2;ID4=0;

If you would like to receive confirmation SMS write “+” before SMS command:
++;ID1=5;ID2=30;ID3=2;ID4=0;

9.4 DELAY BEFORE DIAL – DD

If you would like to have a delay before unit starts dialing procedure use DD – delay before dialing parameter.

Default values:

GSM-VAC4+ PROGRAMMING TABLE		
SIM CARD PHONE BOOK		
Name	Number (Default)	Description
DDN		ON/OFF input delay
DD1		Delay before dialing for Input 1
DD2		Delay before dialing for Input 2
DD3		Delay before dialing for Input 3
DD4		Delay before dialing for Input 4

Example:

GSM-VAC4+ PROGRAMMING TABLE		
SIM CARD PHONE BOOK		
Name	Number	Description
DDN	15	15 seconds delay for ON/OFF input
DD1	5	5 seconds delay before dialing for Input 1
DD2	0	No delay before dialing for Input 2
DD3	0	No delay before dialing for Input 3
DD4	10	10 seconds delay before dialing for Input 4

9.4.1 DD remote programming by SMS

For the upper example send the following SMS from the host phone to the GSM-VAC4+:
;DDN=15;DD1=5;DD2=0;DD3=0;DD4=10;

If you would like to receive confirmation SMS write “+” before SMS command:
++;DDN=15;DD1=5;DD2=0;DD3=0;DD4=10;

9.5 PROGRAMMING OUTPUT STATUS - OS

GSM-VAC4+ device has 4 open collector outputs and each of them can be programmed through network in a different way: as a bi-stable or mono-stable (pulse) output. The programming time is in seconds.

Typical connection for the output:

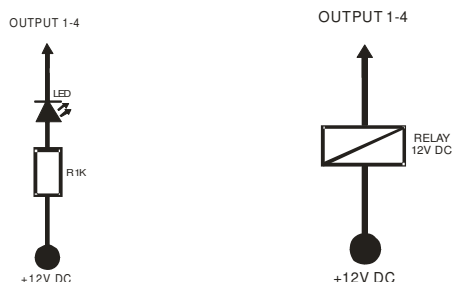

9.5.1 Programming table for output status

Default values:

GSM-VAC4+ PROGRAMMING TABLE		
SIM CARD PHONE BOOK		
Name	Number (Default)	Description
OS1	1	Status for the 1 st output – enabled
OS2	1	Status for the 2 nd output – enabled
OS3	1	Status for the 3 rd output – enabled
OS4	1	Status for the 4 th output – enabled

Example:

GSM-VAC4+ PROGRAMMING TABLE		
SIM CARD PHONE BOOK		
Name	Number	Description
OS1	1	ON/OFF mode output
OS2	0	Disabled output
OS3	20	20 second pulse output
OS4	5	5 second pulse output

9.5.2 OS remote programming by SMS

For the upper example send the following SMS from the host phone to the GSM-VAC4+:
;OS1=1;OS2=0;OS3=20;OS4=5;

If you would like to receive confirmation SMS write “+” before SMS command:
++;OS1=1;OS2=0;OS3=20;OS4=5;

9.6 DIRECT ALARM OUTPUT – OD

If you would like to activate a local alarm (siren) you can program any GSM-VAC4+ output for this function. OD5 to OD8 are links between fictive inputs like telephone line failure, GSM failure to dedicated output.

Type of the Output (ON/OFF or pulse time) is determined with parameter **OS**.

At the same time you can also control the outputs remotely by SMS or DTMF commands.

Possible programming parameters:

GSM-VAC4+ PROGRAMMING TABLE		
SIM CARD PHONE BOOK		
Name	Output	Description
OD1		No direct connection between input and output
OD2		No direct connection between input and output
OD3		No direct connection between input and output
OD4		No direct connection between input and output
OD5		Telephone line failure (only MC&VMC versions)
OD6		GSM network failure
OD7		System tamper
OD8		System ON/OFF (any of outputs)

9.6.1 Programming table for OD – direct alarm output

It is possible to choose different combinations between outputs and inputs

Example:

GSM-VAC4+ PROGRAMMING TABLE		
SIM CARD PHONE BOOK		
Name	Output	Description
OD1	1	Alarm on IN1 trigger output 1
OD2	0	No direct connection between input and output
OD3	0	No direct connection between input and output
OD4	0	No direct connection between input and output
OD5	X	Telephone line failure (only MC&VMC versions)
OD6	2	GSM network failure on output 2
OD7	4	System tamper on output 4
OD8	3	System ON/OFF on output 3

9.6.2 OD remote programming by SMS

For the upper example send the following SMS from the host phone to the GSM-VAC4+:
;OD1=1;OD6=2;OD7=4;OD8=3;

If you would like to receive confirmation SMS write “+” before SMS command:

++;OD1=1;OD6=2;OD7=4;OD8=3;

9.7 INPUTS AND TELEPHONE NO. LINKING - LN

It is possible to link each number or any combination of numbers to any of the four corresponding inputs.

9.7.1 Programming table for linking the inputs and telephone numbers – LN

Default values:

GSM-VAC4+ PROGRAMMING TABLE		
SIM CARD PHONE BOOK		
Name	Number (Default)	Description
LN1		Input & telephone No. linking for 1 st alarm input (TN1 – TN0)
LN2		Input & telephone No. linking for 2 nd alarm input (TN1 – TN0)
LN3		Input & telephone No. linking for 3 rd alarm input (TN1 – TN0)
LN4		Input & telephone No. linking for 4 th alarm input (TN1 – TN0)
LN5		Power down and telephone No. linking (TN1 – TN0)
LN6		Low Battery and telephone No. Linking (TN1 – TN0)
LN7		Periodic test SMS and telephone No. linking (TN1 – TN0)
LN8		SIM card refill and telephone No. linking (TN1 – TN0)
LN9		Tamper switch and telephone No. linking (TN1 – TN0)

Example:

GSM-VAC4+ PROGRAMMING TABLE		
SIM CARD PHONE BOOK		
Name	Number	Description
LN8	12	Refill SIM – SMS is sent to TN1 & TN2
LN1	13	Input1 is called/sent SMS to TN1 & TN3
LN2	123	Input2 is called/sent SMS to TN1, TN2 & TN3
LN3	5	Input3 is called/sent SMS to TN5
LN4	45	Input4 is called/sent SMS to send to TN4 & TN5
LN7	12	Periodic Test SMS is sent to TN1 & TN2

9.7.2 LN remote programming by SMS

For the upper example send the following SMS from the host phone to the GSM-VAC4+:
;LN8=12;LN1=13;LN2=123;LN3=5;LN4=45;LN7=12;

If you would like to receive confirmation SMS write “+” before SMS command:
++;LN8=12;LN1=13;LN2=123;LN3=5;LN4=45;LN7=12;

9.8 MAIN POWER LOST AND TELEPHONE NO. LINKING – LN5

GSM-VAC4+ sends an SMS message in case of the main power failure. SMS message is sent to user. The default SMS is “Main Power Lost”. You can also program how long the unit can stay without power before sending this message. The default time is 5 second (parameter MAIN).

9.8.1 Programming table for the MAIN POWER LOST and telephone numbers linking

Default values:

GSM-VAC4+ PROGRAMMING TABLE		
SIM CARD PHONE BOOK		
Name	Number (Default)	Description
LN5		Telephone number from TN1 to TN0

Example:

GSM-VAC4+ PROGRAMMING TABLE		
SIM CARD PHONE BOOK		
Name	Number	Description
LN5	12	Main Power Lost SMS is sent to TN1 and TN2

9.8.2 LN remote programming by SMS

For the upper example send the following SMS from the host phone to the GSM-VAC4+:
;LN5=12;

If you would like to receive confirmation SMS write “+” before SMS command:
;+LN5=12;

9.9 LOW BATTERY AND TELEPHONE NO. LINKING – LN6

GSM-VAC4+ can control battery level and sends 3 SMS messages when following voltage level on battery is reached: 11,5V, 10,5V and 9V. It sends the “Low Battery” and battery level in volts SMS message together.

The low battery level can be detected when the unit works without main power supply. Should the battery power rise again above 11,5V GSM-VAC4+ sends an SMS message with the following text: “Low Battery restored”.

NOTE: The “Low battery” event is detected when the GSM-VAC4+ operates only with a backup battery and it is not connected on the Main Power Supply.

9.9.1 Programming table for LOW BATTERY and telephone numbers linking

Default values:

GSM-VAC4+ PROGRAMMING TABLE		
SIM CARD PHONE BOOK		
Name	Number (Default)	Description
LN6		Telephone number from TN1 to TN0

Example:

GSM-VAC4+ PROGRAMMING TABLE		
SIM CARD PHONE BOOK		
Name	Number	Description
LN6	12	Low Battery SMS is sent to TN1 and TN2

9.9.2 LN6 remote programming by SMS

For the upper example send the following SMS from the host phone to the GSM-VAC4+:
;LN6=12;

If you would like to receive confirmation SMS write “+” before SMS command:
;+LN6=12;

9.10 MAIN POWER LOST FILTER PARAMETER - MAIN

Parameter MAIN determines length of the pulse which is required to trigger the alarm after the main power is lost. Time can be set between 1 and 9999 seconds. The default value is 5 seconds.

For example: When GSM-VAC4+ is without main power supply for more than 5 seconds (default) it sends an SMS message with the following text: “Main Power Lost”.

Should the main power return GSM-VAC4+ sends an SMS message with the following text: “Main Power restored”.

9.10.1 Programming table for “MAIN POWER LOST” filter – MAIN

Default values:

GSM-VAC4+ PROGRAMMING TABLE		
SIM CARD PHONE BOOK		
Name	Number (Default)	Description
MAIN	5	Main Power Lost filter (5 seconds default)

Example:

GSM-VAC4+ PROGRAMMING TABLE		
SIM CARD PHONE BOOK		
Name	Number	Description
MAIN	9	Main Power Lost filter

9.10.2 MAIN POWER LOST - filter remote programming by SMS

For the upper example send the following SMS from the host phone to the GSM-VAC4+:
;MAIN=9;

If you would like to receive confirmation SMS write “+” before SMS command:
;+MAIN=9;

9.11 CLIP FUNCTION PARAMETER – TC

Ten telephone numbers which are stored into the phone book from TN1 to TN0 can manage following functions using CLIP (Calling Line Identification Presentation) without making any cost to the user GSM bill.

- ⇒ Trigger one of the GSM-VAC4+ Output (parameter 1-4)
- ⇒ Switch the system ON/OFF (parameter 5)
- ⇒ System control with “Call-back” function (parameter 6)

**NOTE: With one telephone number you can control only one function (for example trigger only first output)!
 To activate the CLIP function you must cancel call after 1-3 rings!**

9.11.1 Programming table to define the CLIP functions – TC

GSM-VAC4+ PROGRAMMING TABLE		
SIM CARD PHONE BOOK		
Name	Number	Description
TC1	x	First CLIP telephone number = TN1
TC2	x	Second CLIP telephone number = TN2
TC3	x	Third CLIP telephone number = TN3
TC4	x	Forth CLIP telephone number = TN4
TC5	x	Fifth CLIP telephone number = TN5
TC6	x	Sixth CLIP telephone number = TN6
TC7	x	Seventh CLIP telephone number = TN7
TC8	x	Eight telephone number = TN8
TC9	x	Ninth CLIP telephone number = TN9
TC0	x	Tenth CLIP telephone number = TN0

- ⇒ **X=1-4** OUTPUT1 to OUTPUT4 controlling
- ⇒ **X=5** System ON/OFF
- ⇒ **X=6** Call back function

TC1 triggers OUTPUT3, TC2 switches the system ON/OFF and TC3 makes a call back to the user's phone.

Example:

GSM-VAC4+ PROGRAMMING TABLE		
SIM CARD PHONE BOOK		
Name	Number	Description
TC1	3	1 st CLIP activates the Output 3
TC2	5	2 nd CLIP switches system OFF/ON
TC3	6	3 rd CLIP calls back from device to user

9.11.2 TC parameter remote programming by SMS

For the upper example send the following SMS from the host phone to the GSM-VAC4+:
;TC1=3;TC2=5;TC3=6;

If you would like to receive confirmation SMS write “+” before SMS command:
;+TC1=3;TC2=5;TC3=6;

1.1 AUTOMATIC INPUT BLOCK SYSTEM

With automatic input block system you can define the number of alarm events that can be triggered in chosen interval before the systems blocks sending alarm events to telephone numbers.

AT – AT parameter defines the number of alarms that have to be triggered before automatic input system blocks sending alarm events.

IT – IT parameter defines the interval in which previous number of alarms has to be triggered before automatic input system blocks sending alarm events.

IB – IB parameter defines how long (in seconds) sending of alarm events is blocked when automatic input block system enables.

Parameters can be set for different inputs with numbers from 1 to 4.

Default values:

GSM-VAC4+ PROGRAMMING TABLE		
SIM CARD PHONE BOOK		
Name	Number (Default)	Description
AT	0	Default value for number of alarm triggers
IT	180	Default value for interval length
IB	3600	Default value for amount of time block system is enabled

Example:

GSM-VAC4+ PROGRAMMING TABLE		
SIM CARD PHONE BOOK		
Name	Number	Description
AT1	10	10 alarm triggers must occur to enable block system
IT1	125	Interval length is 125 second
IB1	600	Block system is enabled for 600 seconds (10 minutes)
AT3	5	5 alarm triggers must occur to enable block system
IT3	720	Interval length is 720 second (12 minutes)
IB3	3900	Block system is enabled for 3900 seconds (1 hour and 5 minutes)

Input 1 will be blocked for 10 minutes if 10 alarm events are triggered within 125 seconds
Input 3 will be blocked for 1 hour and 5 minutes if 5 alarm events are triggered within 12 minutes.

1.1.1 The input time window remote programming by SMS

For the upper example send the following SMS from the host phone to the GSM-VAC4+:
;AT1=10;IT1=125;IB1=600;AT3=5;IT3=720;IB3=3605

If you would like to receive confirmation SMS write “+” before SMS command:
+;AT1=10;IT1=125;IB1=600;AT3=5;IT3=720;IB3=3605

1.2 SECURITY LEVEL - SL

SL parameter form SL0 to SL10 defines which telephone number stored into the phone book from TN1 – TN0 can enter into programming and remote control unit of the GSM-VAC4+ (dialing the GSM-VAC4+ phone number or sending the SMS).

NOTE: When the SL level is 0, an access to the GSM-VAC4+ is possible from any phone!

NOTE: Before any SL number is programmed the GSM-VAC4+ can accept ALL CALLS. Remote SMS programming and remote controlling is possible from any phone!

1.2.1 Programming table for security level definition – SL

Default values:

GSM-VAC4+ PROGRAMMING TABLE		
SIM CARD PHONE BOOK		
Name	Number (Default)	Description
SL	0	All calls and SMS will be accepted
SL	1	Only number stored under parameter TN1 has access to unit
SL	2	Numbers stored under parameters TN1 to TN2 have access to unit
SL	3	Numbers stored under parameters TN1 to TN3 have access to unit
SL	4	Numbers stored under parameters TN1 to TN4 have access to unit
SL	5	Numbers stored under parameters TN1 to TN5 have access to unit
SL	6	Numbers stored under parameters TN1 to TN6 have access to unit
SL	7	Numbers stored under parameters TN1 to TN7 have access to unit
SL	8	Numbers stored under parameters TN1 to TN8 have access to unit
SL	9	Numbers stored under parameters TN1 to TN9 have access to unit
SL	10	Numbers stored under parameters TN1 to TN0 have access to unit

1.2.2 SL parameter remote programming by SMS

To enable programming and remote control access to only first five telephone numbers send the following SMS from the host phone to the GSM-VAC4+:

;SL=5;

If you would like to receive confirmation SMS write “+” before SMS command:

;++SL=5;

1.3 PREPAID CARD CREDIT AND VALIDITY INFORMATION

If prepaid SIM card is used in GSM-VAC4+ it is very useful if we can receive the information about remaining credit.

GSM providers have different ways to get the credit information. At the moment we can hold up 3 different strings.

GSM-VAC4+ automatically sends low credit SMS message when the credit goes below 3€!

1.3.1 Programming prepaid card credit and validity string

Example:

GSM-VAC4+ PROGRAMMING TABLE		
SIM CARD PHONE BOOK		
Name	Number	Description
CC1	*XXX#	* + Number +#
CC2	4916	TIM Italy
CC3	404	Vodafone

CC1=*448# for SIMOBIL; *123# for MOBITEL

This method can be used by any user that receive credit messages like that on their GSM phone (press *+provider number+” & call button).

CC2 method is dedicated to TIM mobile provider.

CC3 method is dedicated to Vodafone mobile provider

1.3.2 CC parameter for remote programming

For the upper example send the following SMS to GSM-VAC4+:

1. CC1 (Simobil) ;**CC1=*448#;**
2. CC2 (TIM) ;**CC2=4916;**
3. CC3 (Vodafone) ;**CC3=404;**

1.4 SET-UP PARAMETERS

- ⇒ **CRE** – repetition of calling sequences. With the number from 1 to 99 we define how often the sequence is repeated in case the number is busy or not answered. The default value is set to number “3”.
- ⇒ **HTN** – hidden telephone number. This function (“0” value) is used in order to conceal the telephone number of the GSM-VAC4+ device. The default value is set to “1” which means that the number is displayed.
- ⇒ **SCV** – SIM card validity. The period of valid operating time varies with different GSM network providers. The value can be programmed from 1 to 360 days. The default value does not presume any kind of expiry warning.

After the SIM refill it is necessary to send a command SMS to the ZEUS4 and reset the counter.

;SCV=XXX;

Where XXX are number of days. For example in Slovenia SCV are 90 and in Italy 360 days.

NOTE: The parameter SCV must be sent by SMS command and should not be programmed directly on SIM card!

- ⇒ **MNF** - When it is necessary to fix the GSM network to one provider we can use the MNF parameter. The MNF parameter switches automatic network searching to manual.

For example:

MCC/MNC code for Simobil is 29340, Mobitel is 29341, TIM is 22201, and Vodafone Italy is 22210;

More information about national MCC/MNC codes can be acquired at:

<http://www.activexperts.com/activsms/networkcodes/>

- ⇒ **RAN** – Number of rings before GSM-VAC4+ answers. With this command you can set the ring counter and unit automatically answers after programmed number of rings with this parameter. The default value is 5 rings.

⇒ **TST** – A test SMS is sent periodically. GSM-VAC4+ can send the test message in the interval ranging from 1hour up to 240 hours.

Example: if the TST value is set to 12, the numbers linked to “LN7” receive a test message every 12 hours.

⇒ **ALC** – ALC parameter, if adjusted to 1, enables that log is automatically cleared after it becomes full.

⇒ **LOGN** – LOGN parameter defines the number of event log messages sent by SMS when **;PLOG;** command is sent to the device

⇒ **RNT** – RNT parameter defines how long (in seconds) the device is dialing telephone number before switching to another.

⇒ **LOT** – LOT parameter defines how long (in seconds) the device is connected to dialed unit.

⇒ **ARST** – ARST parameter defines periodic auto restart time (in hours) of the device.

⇒ **CID** – CID parameter enables Contact ID communication between the device and Central Monitoring Station

⇒ **LED** – LED parameter enables you to turn LED lights on or off (default is 1 – enabled).

⇒ **LNG** – This command switches between the pre-programmed languages:

Example:

0=English, 1=Italian, 2=Slovenian, 3=Croatian, 4=Dutch

The default language is English.

Programming table for GSM-VAC4+ Set-up parameters

Default values:

GSM-VAC4+ PROGRAMMING TABLE		
SIM CARD PHONE BOOK		
Name	Number (Default)	Description
CRE	3	Number of dialing attempts (1 – 99)
HTN	1	Hidden telephone number (1= displayed, 0 = hidden)
RAN	5	Number of rings before answering
SCV	for prepaid SIM	SIM card time validity 1-360 days
MNF		Automatic network searching (default)
LNG	0	Switch between different languages
TST		Periodic test SMS - disabled

Example:

GSM-VAC4+ PROGRAMMING TABLE		
SIM CARD PHONE BOOK		
Name	Number	Description
CRE	2	Number of dialing attempts - 2
HTN	0	Hidden telephone number of the GSM-VAC4+
RAN	5	The unit will answer after 5 rings
SCV	360	Refill time is 360 days
MFN	29340	Manual fixing of the GSM provider (Simobil)
LNG	1	Switch on Italian language
TST	24	24 hours periodic test SMS

1.4.1 Set-up parameters programming by SMS

For the upper example send the following SMS from the host phone to the GSM-VAC4+:
;CRE=2;HTN=0;SCV=360;MFN=29340;TST=24;RAN=5;MIC1=2;SPK=80;****

If you would like to receive confirmation SMS write “+” before SMS command:
;+CRE=2;HTN=0;LPA=360;MFN=29340;TST=24;RAN=5;MIC1=2;SPK=80;****

1.5 SMS MESSAGES EDITOR

You can write and send a short SMS message for each alarm input. The default message is English, but it is possible to change language with LNG parameter. Each message is built from 3 parts and user can write the first (User Location) and the second (alarm event) part of the message. Unit adds the third part (alarm event description) automatically. Language of the 3rd part may be changed by LNG parameter. The message is stored in the SIM phone book so you should add any number for correct operation.

1	2	3	4	5	6	7	8	9	10	11	12	13	14	15	16
#	0	U	S	E	R		L	O	C	A	T	I	O	N	
#	1	I	N	P	U	T		1							
#	2	I	N	P	U	T		2							
#	3	I	N	P	U	T		3							
#	4	I	N	P	U	T		4							

NOTE: Message should not be longer than 14 characters! Space is also counted as one character!

1.5.1 Alarm messages remote editing by SMS command

Send the following SMS to the unit:
;#0USER LOCATION=0;#1INPUT 1=1;#2INPUT 2=2;#3INPUT 3=3;#4INPUT 4=4;****

If you would like to receive confirmation SMS write “+” before SMS command:
;+#0USER LOCATION=0;#1INPUT 1=1;#2INPUT 2=2;#3INPUT 3=3;#4INPUT 4=4;****

2 DTMF REMOTE COMMANDS

NOTE: If you cannot enter into remote mode, check the SL level first!

2.1 DTMF REMOTE COMMAND TABLE

REMOTE COMMAND	ACTION DESCRIPTION
00	All outputs OFF
01	All outputs ON
10	Output 1 OFF
11	Output 1 ON
12	Check the output 1 state (1 beep=ON, 3 beeps=OFF)
20	Output 2 OFF
21	Output 2 ON
22	Check the output 2 state (1 beep=ON, 3 beeps=OFF)
30	Output 3 OFF
31	Output 3 ON
32	Check the output3 state (1 beep=ON, 3 beeps=OFF)
40	Output 4 OFF
41	Output 4 ON
42	Check the output4 state (1 beep=ON, 3 beeps=OFF)
51	Input 1 status checking (1 beep=alarm, 3 beeps=normal)
52	Input 2 status checking (1 beep=alarm, 3 beeps=normal)
53	Input 3 status checking (1 beep=alarm, 3 beeps=normal)
54	Input 4 status checking (1 beep=alarm, 3 beeps=normal)
60	System OFF (3 beeps)
61	System ON (1 beep)
62	System status verification (1 beep=ON, 3 beeps=OFF)
99	Listen-in ON
*	Does not call this telephone number again
#	Complete interruption of the dialing procedure

3 PRINT-OUT OF THE PARAMETERS

3.1 RECEIVE ALL PARAMETERS (PALL)

By sending this command to GSM-VAC4+ you receive 14 SMS messages with all parameters that are currently programmed in the unit:

;PALL;

3.2 RECEIVE TELEPHONE NUMBERS (PTN)

By sending this command to GSM-VAC4+ you receive SMS message with all currently programmed telephone numbers (TN1 – TN10):

;PTN;

3.3 RECEIVE LINKS (PLN)

By sending this command to GSM-VAC4+ you receive SMS message with all currently programmed links (LN1 –LN9):

;PLN;

3.4 RECEIVE INPUT PARAMETERS (PIN)

By sending this command to GSM-VAC4+ you receive SMS message with all currently programmed Input parameters (IN1 – IN4):

;PIN;

3.5 RECEIVE INPUT FILTER VALUE (PID)

By sending this command to GSM-VAC4+ you receive SMS message with all currently programmed Input filters (ID1 – ID4 and ION):

;PID;

3.6 RECEIVE DELAY BEFORE DIAL VALUE (PDD)

By sending this command to GSM-VAC4+ you receive SMS message with all currently programmed Input filters (DD1 – DD4 and DON):

;PDD;

3.7 RECEIVE CLIP IDENTIFICATION FUNCTIONS (PTC)

By sending this command to GSM-VAC4+ you receive SMS message with all currently programmed CLIP function to dedicated telephone number (TN1 – TN0) and number of rings before answer- RAN:

;PTC;

3.8 RECEIVE ACCESS TELEPHONE NUMBERS (PSL)

By sending this command to GSM-VAC4+ you receive SMS message with programmed SL level:
;PSL;

3.9 RECEIVE OUTPUT PARAMETERS (POS)

By sending this command to GSM-VAC4+ you receive SMS message with all currently programmed Outputs parameters (OS1 – OS4):
;POS;

3.10 RECEIVE LINK FOR LOCAL ALARM OUTPUT (POD)

By sending this command to GSM-VAC4+ you receive SMS message with all currently programmed direct output alarm links (OD1 – OD8):
;POD;

3.11 RECEIVE ALL PROGRAMMED SMS MESSAGES (P#)

By sending this command to GSM-VAC4+ you receive SMS message with all currently programmed alarm SMS messages (#0 - #4):
;P#;

3.12 RECEIVE THE POWER LEVEL ON THE UNIT (PPWR)

By sending this command to GSM-VAC4+ you receive SMS message with current main power level in volts or current battery voltage when the unit runs on the backup battery:
;PPWR;

3.13 RECEIVE SET UP PARAMETERS VALUE (PPA)

By sending this command to GSM-VAC4+ you receive SMS message with all currently programmed Setup parameters (LPA, TST, CRE, MNF, MAIN...):
;PPA;

3.14 STATE OF THE CREDIT FOR THE PREPAID CARD

By sending this command to GSM-VAC4+ you receive SMS message with Credit amount on your prepaid SIM card:
;PCCX;

Where X is the number of programmed prepaid card provider.

3.15 STATE OF THE OUTPUTS (PORC)

By sending this command to GSM-VAC4+ you receive SMS message with current outputs state.
;PORC;

4 CHECKING AND CHANGING THE SYSTEM STATUS (ON/OFF)

4.1 CHECKING SYSTEM STATUS BY SMS COMMAND

By sending this command to GSM-VAC4+ you receive SMS message with state of the system:
;SYS;

Return SMS can be:

- ⇒ ;SYS= ON; System is ON (active inputs)
- ⇒ ;SYS= OFF; System is OFF (inputs are not active)

4.2 CHECKING SYSTEM STATUS BY DTMF COMMAND

If you would like to check the system status (system ON/OFF) with DTMF command then you should call the GSM-VAC4+ and after beep press command “**62**”. You can hear following responses:

- ⇒ 1 beepsystem is ON (all alarm inputs are enable)
- ⇒ 3 beeps.....system is OFF (all alarm inputs are disable)

4.3 CHANGING SYSTEM STATUS TO ON (SYSTEM ON)

By sending this command to GSM-VAC4+ it switches the system ON.
;SYS=1;

If you would like to receive confirmation SMS write “+” before SMS command:
++;SYS=1;

4.4 CHANGING SYSTEM STATUS TO OFF (SYSTEM OFF)

By sending this command to GSM-VAC4+ it switches the system OFF.
;SYS=0;

If you would like to receive confirmation SMS write “+” before SMS command:
++;SYS=0;

5 CHECKING THE INPUT STATUS

You can get the information's about inputs status on two different ways:

- ⇒ Call GSM-VAC4+ number and use DTMF commands
- ⇒ Send SMS command and receive return SMS message with input status.

5.1 CHECKING THE INPUT STATUS BY DTMF

Call GSM-VAC4+ number and after short beep press the DTMF command. Response with 1 beep means that the input is in alarm state and response with 3 beeps means that the input is in normal (stand-by) state.

REMOTE COMMAND	ACTION DESCRIPTION
51	Input 1 status checking (1 beep=alarm, 3 beeps=normal)
52	Input 2 status checking (1 beep=alarm, 3 beeps=normal)
53	Input 3 status checking (1 beep=alarm, 3 beeps=normal)
54	Input 4 status checking (1 beep=alarm, 3 beeps=normal)

5.2 CHECKING THE INPUT STATUS BY SMS (INS)

By sending this command to GSM-VAC4+ you receive SMS message with all Input status:
;INS;

Return SMS message is:

- ⇒ ;INS(1-4)=(OPEN-ON) – alarm loop is open and the input is in alarm state
- ⇒ ;INS(1-4)=(OPEN-OFF) – alarm loop is open and the alarm input is in idle state
- ⇒ ;INS(1-4)=(LOW-ON) – alarm loop is close on GND and the input is in alarm state
- ⇒ ;INS(1-4)=(LOW-OFF) – alarm loop is close on the GND and the alarm input is in idle state
- ⇒ ;INS(1-4)=(HGHI-ON) – alarm loop is close on +12MCC and the input is in alarm state
- ⇒ ;INS(1-4)=(HIGH-OFF) – alarm loop is close on +12V and the alarm input is in idle state
- ⇒ ;SYS= ON;
- ⇒ ;SYS= OFF;

6 OUTPUTS REMOTE CONTROL

You can use outputs remote control in two different ways:

- ⇒ calling GSM-VAC4+ and use DTMF commands
- ⇒ send the SMS command and receive the SMS message with output status

6.1 OUTPUTS REMOTE CONTROL BY SMS COMMAND

By sending this command to GSM-VAC4+ the output X is switched ON:

;ORCX=1;

For X please choose one of the output numbers from 1 to 4.

By sending this command to GSM-VAC4+ the output X is switched OFF:

;ORCX=0;

For X please choose one of the output numbers from 1 to 4.

If you would like to receive SMS message with the Output status write “+” before SMS command:

;+ORCX=1;****

For X please choose one of the output numbers from 1 to 4.

Return SMS message is:

ORCX=(ON)

Where X is one of the output numbers from 1 to 4.

6.2 OUTPUTS REMOTE CONTROL BY DTMF COMMAND

After the short beep press the DTMF command. Response with 1 beep means that the output is active (ON) and response with 3 beep means that the output is in inactive (OFF) mode.

11	Output 1 ON (bi-stable) or ON for mono-stable
12	Check the output 1 state (1 beep=ON, 3 beeps=OFF)
10	Output 1 OFF (bi-stable) or ON for mono-stable
20	Output 2 OFF (bi-stable) or ON for mono-stable
21	Output 2 ON (bi-stable)
22	Check the output 2 state (1 beep=ON, 3 beeps=OFF)
30	Output 3 OFF (bi-stable) or ON for mono-stable
31	Output 3 ON (bi-stable)
32	Check the output3 state (1 beep=ON, 3 beeps=OFF)
40	Output 4 OFF (bi-stable) or ON for mono-stable
41	Output 4 ON (bi-stable)
42	Check the output4 state (1 beep=ON, 3 beeps=OFF)

Use 12, 22, 32 and 42 DTMF command to verify the output state. With DTMF command “**00**” you may put all outputs **OFF** and with command “**01**” all outputs **ON** in the same time.

7 CHANGING PARAMETERS USING THE SMS COMMAND

All programming parameters for GSM-VAC4+ can also be sent by SMS command. Each SMS command should start and stop with semicolon. If the confirmation SMS is needed put “+” at the beginning of the command SMS.

The first SMS is SMS with telephone numbers (TN1 – TN10). If you would like to check which telephone numbers are programmed in GSM-VAC4+ please use the following command:

;PTN;

Return SMS is (example):

;TN0=0;TN1=0;TN2=0;TN3=0;TN 4=0;TN5=0;TN6=0;TN7=0;TN 8=0;TN9=0;

If you would like to enter telephone numbers in to GSM-VAC4+ you can use the following example:

**;
TN0=040713470;TN1=+38643364850;TN2=041255630;TN3=0;TN4=0;TN5=0;TN6=0;TN 7=0;TN8=0;TN9=0;**

If you would like to receive confirmation SMS write “+” before SMS command:

**;
+TN0=040713470;TN1=+38643364850;TN2=041255630;TN3=0;TN4=0;TN5=0;TN6=0;TN 7=0;TN8=0;TN9=0;**

Return SMS from GSM-VAC4+ is:

**;
TN0=040713470;TN1=+38643364850;TN2=041255630;TN3=0;TN4=0;TN5=0;TN6=0;TN 7=0;TN 8=0;TN9=0;**

NOTE: You can use the same programming procedure for all parameters.

It is also possible to change different parameters with one SMS. Consider that the SMS message should not be longer than **160 characters** (included space characters).

If you would like to change the following parameters **TN1, IN1, IN2, OS3, OS4; ID1, LN1 and CRE** and would like to receive confirmation SMS, try next example:

++;TN1=+38640713470;IN1=1;IN2=1;OS3=15;ID1=120;LN1=1;CRE=4;

Send SMS message to GSM-VAC4+ telephone number and in a few seconds you receive SMS message from GSM-VAC4+. The sentence of the SMS must be the same as the one you have sent to GSM-VAC4+ before.

8 APPENDIX TO GSM-VAC4+ MANUAL FOR CONTACT-ID (REV6)

1. Contact ID enabling:

- CID=1 Contact ID enabled
- CID=0 Contact ID disabled

2. The Central Monitoring Station (CMS) telephone number:

- TN11= XXXXXXXX – primary CMS telephone number
- TN12= XXXXXXXX – secondary CMS telephone number

(XXXXXXX= telephone number)

3. The client account number (4 digits)

- #0ACCOUNT=1111

(1111= default account number)

ACCOUNT may be any text (max 14 characters), but the command may be also without text:

For example: #0=5555

4. The Contact ID (CID) codes for inputs

- #1INPUT1=130 or only #1=130
- #2INPUT2=110 or only #2=110
- #3INPUT3=120 or only #3=120
- #4INPUT4=100 or only #4=100

By default the CID codes for inputs are

130 – Burglary for Input 1

110 – Fire for Input 2

120 – Panic for Input 3

100 – Medical for Input 4

The CID code for each input is possible to change with any valid CID code.

5. The CID System Auto-test

- TST =24

GSM-VAC4+ will automatically send the Auto-test report every 24 hours to the CMS. The testing period is programmable.

9 TECHNICAL SPECIFICATION

Description	Value
Power Supply	13,8 - 14,5V DC
Battery backup (optional)	12V/1,2Ah
Current consumption - peak	2A
Current consumption - transmitting mode	250mA
Current consumption - idle mode	40mA
Tri band GSM module (QUAD optional)	900/1800/1900 MHz
PCB dimensions	105 × 80 mm
Unit dimensions	118 × 170 × 60 mm
Unit dimensions - IP56 box	155 × 220 × 82 mm
Antenna SMA	1
Weight (without battery)	550g
Power Supply	13,8 - 14,5V DC
Battery backup (optional)	12V/1,2Ah
Current consumption - peak	2A
Current consumption - transmitting mode	250mA
Alarm inputs	4
GSM Priority input	0
Alarm outputs (open collector)	4
ON/OFF input	1
12V DC Power Supply input	Y
12/24V AC/DC Power Supply input	N
Backup battery input	Y
Telephone line interface	N
Alarms calls over PSTN line	N
No. of alarm SMS per unit	4
No. of prerecorded messages	4
Programmed telephone numbers	10
Anti-tamper protection	Y
CLIP numbers	80
Event log buffer	1000
