

FM1803-2 Furlmatic Windcharger

Now with new 3 bladed
aerofoil turbine!

Are you living off grid?

Do you need power at a remote site?

Take advantage of the abundant power of the wind to generate your own free power using the Rutland FM1803-2 Furlmatic Windcharger. The FM1803-2 needs only a light breeze to start generating power for charging batteries so you have the convenience of energy stored for whenever you need it. Typically the 12V or 24V battery power can be used for:

- *Low energy lighting*
- *Pumps*
- *Refrigerators*
- *Telecommunications equipment*
- *Computers & TV's*
- *230V appliances can be operated through an inverter*



FM1803-2 model
3 blade design with
MPC1 controller inset



Living off grid

Where grid power is not available the FM1803-2 provides a cost effective solution, charging batteries to deliver 12/24V power which can also be inverted to 230V AC.

The FM1803-2 can deliver sufficient power for most daily needs with only occasional use of a generator for high energy consuming appliances, e.g. domestic washing machine.

Where a generator is already used the FM1803-2 will soon reduce energy costs and pay for itself in convenience. Direct fuel costs and engine wear and running time will be noticeably reduced.

Power at Remote and Inaccessible Sites

Professionals providing services such as telecommunications and monitoring at remote locations will find using wind power immediately cost effective and long term convenient. Site visits to change batteries will be reduced and battery life extended.

A clean source of energy and it saves you money!

- *Rutland Windchargers are an environmentally friendly way of generating power*
- *Battery life is extended as the continuous charging reduces the number of deep discharge cycles.*
- *Where generators are in use running and maintenance costs will be reduced.*

Typical Applications

Marlec's FM1800 and FM1803 models have been used worldwide since 1989 in a variety of applications, eg:

- *Remote homes*
- *Rural Clinics*
- *Scientific & Military Field Applications*
- *Telecommunications sites*
- *Portable power for travelling shows*



MPC1 Electronic controller
with digital display is included.

FM1803-2 Furlmatic Windcharger System

Updated and more powerful!

Technical Features

The FM1803-2 Furlmatic Windcharger with its robust 3-bladed wind turbine is supplied with its purpose designed controller.

- New 3 bladed turbine design combines an efficient profile with a durable injection moulded construction.
- The 3 phase generator has a very low torque enabling power generation to start from just 3m/s (<7mph) windspeed.
- Rutland unique disc type brushless generator design has a high degree of inertia that keeps the turbine spinning between gusts of wind where other designs stop and start. As such the FM1803-2 delivers more power into a battery over a given period than all other commercial turbines of the same diameter that we know of and even some larger turbines.
- Sliprings at the tower top allow the turbine freedom to find the wind over 360° rotation.
- AC power is generated and transmitted to the controller. As the AC is generated at high voltage power losses are low allowing small cable to be used, minimising installation costs.
- Marlec's well established furling tail system is used on the FM1803-2. The tail normally directs the turbine into wind but a simple gravity induced mechanism operates at 15m/s (35mph) to push the turbine off wind thus reducing its speed. This provides protection from the forces exerted on the turbine and tower in very high winds and assures longevity of the product.
- MPC1 Controller incorporates 4 key features; 3 phase transformer to reduce voltage, a rectifier to convert AC to DC an electronic controller and battery overcharge protection.

MPC1 Controller electronics optimise the performance of the turbine to generate more power into the battery. It does this by switching the power ratios between high and low wind speed modes. The digital display keeps the user informed of the status of operation. The MPC1 functions and features are:

- LCD displays: battery voltage, charge in Watts & Amps and low battery voltage warning sign.
- LCD also displays the mode of operation: low wind mode, high wind mode, stall, battery full.
- A switch to start and stall the turbine.
- LED's to indicate operation modes & warnings
- Automatic delayed change of operation to avoid rapid switching. This takes account of short gusts of wind and waits for a sustained higher wind or voltage to be reached before changeover.
- Battery overcharge protection - turbine stall is invoked when the batteries are full at 14.4V & 28.8V @ 25°C thus reducing unnecessary wear and tear on the turbine. It automatically restarts as the battery volts fall to the lower limits of 12.5V & 25V.
- A re-set button allows the user to restart the wind turbine before this lower limit is reached.
- Temperature compensation ensures that the battery voltage switching points are automatically adjusted for ambient temperature to maintain optimum battery performance

How to get Up and Running



Tower - various designs are available that are adaptable to fit the FM1803-2 turbine's post fitting. A pole with an 81mm internal and 91mm external diameter is needed to affix the turbine to the tower. Lattice, freestanding and guyed towers are all suitable depending on the terrain, height and application. Wind loading figures for your tower design are available on request from Marlec.

Batteries – deep cycle lead acid batteries either sealed or unsealed are suitable for charging from the FM1803-2. A minimum capacity of 400Ah @ 12V and 200Ah @ 24V is recommended.

Cable – 3 core cable is required. The thickness to distance recommendations are: up to 50m 1.5mm² (16AWG), up to 100m 2.5mm² (14AWG). Longer distances are possible. The controller should always be located indoors and within 2m cable distance of the battery bank.

Performance Curve

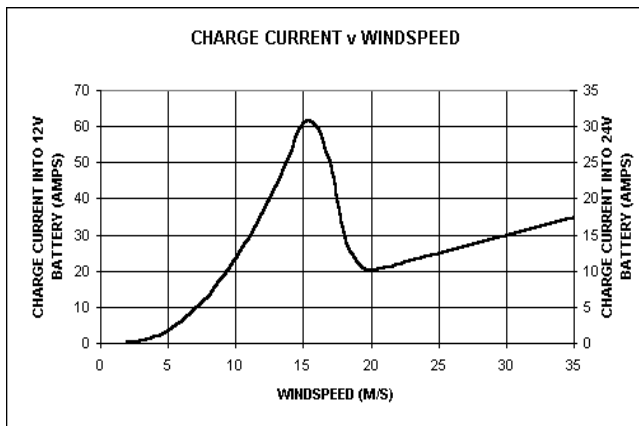

The FM1803-2 Furlmatic wind turbine is common to both the 12V and 24V Controllers. Part numbers: Turbine CA-03/02.

Controllers: 12V CA-04/06, 24V CA-04/07

The FM1803-2 complies with EEC Directive 89/336/EEC ensuring that it does not emit any radiated interference.

Product Dimensions:

Turbine dimensions are shown right

Weights: Turbine on tower 35.32Kg.

Controller: 280x250x140mm 9.94Kg

Shipping Specifications:

1 carton on a pallet: 1200x675x520mm.

Weight 74Kg

At Marlec we continuously strive to improve products and as such specifications may change without notice.

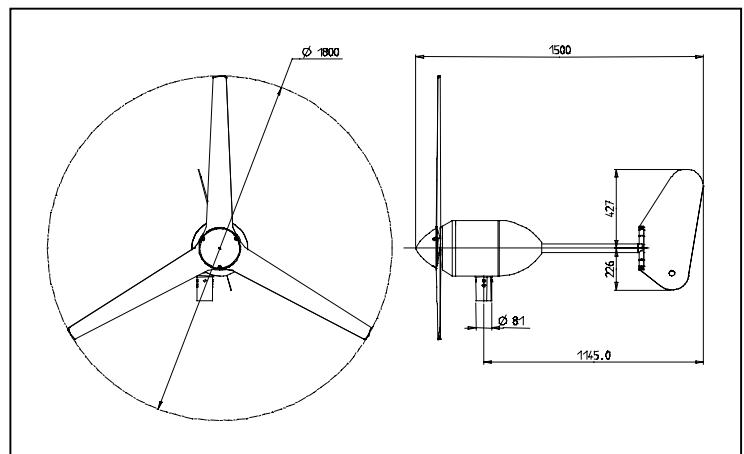

Designed & Manufactured in the UK by

Marlec Engineering Co Ltd

Rutland House, Trevithick Rd, Corby, NN17 5XY

Tel: +44 (0)1536 201588 Fax: +44 (0)1536 400211

sales@marlec.co.uk www.marlec.co.uk

